



Q8



Think about your life.
Accelerated in a
new direction.





Think about mobility. Then multiply it by today's world. Experience a form that redefines the maximum. That enriches every second of your life. The new Audi Q8 impressively combines the emotive line of a sporty coupé with the spaciousness of an SUV. A design that sets new standards. A character that puts self-confidence in a class of its own. Come with us into the 8th dimension.



**Marvel at a form.
Sharpened by character.**

It's the first impression that counts. That goes not just for what you can see, but also for the personality behind the form. The new Audi Q8 embodies both: its exterior design combines an athletic roof line and a coupé-like silhouette to create a powerful character statement – making a lasting impression wherever it goes.

Savour the view.
Brought to life by a statement.





**Discover a detail.
Multiplied by greatness.**

Conviction is not something you can hide. The dominant octagonal Singleframe and the sporty feel of the D-pillar make the new Audi Q8 what it is – an expressive character with true greatness.

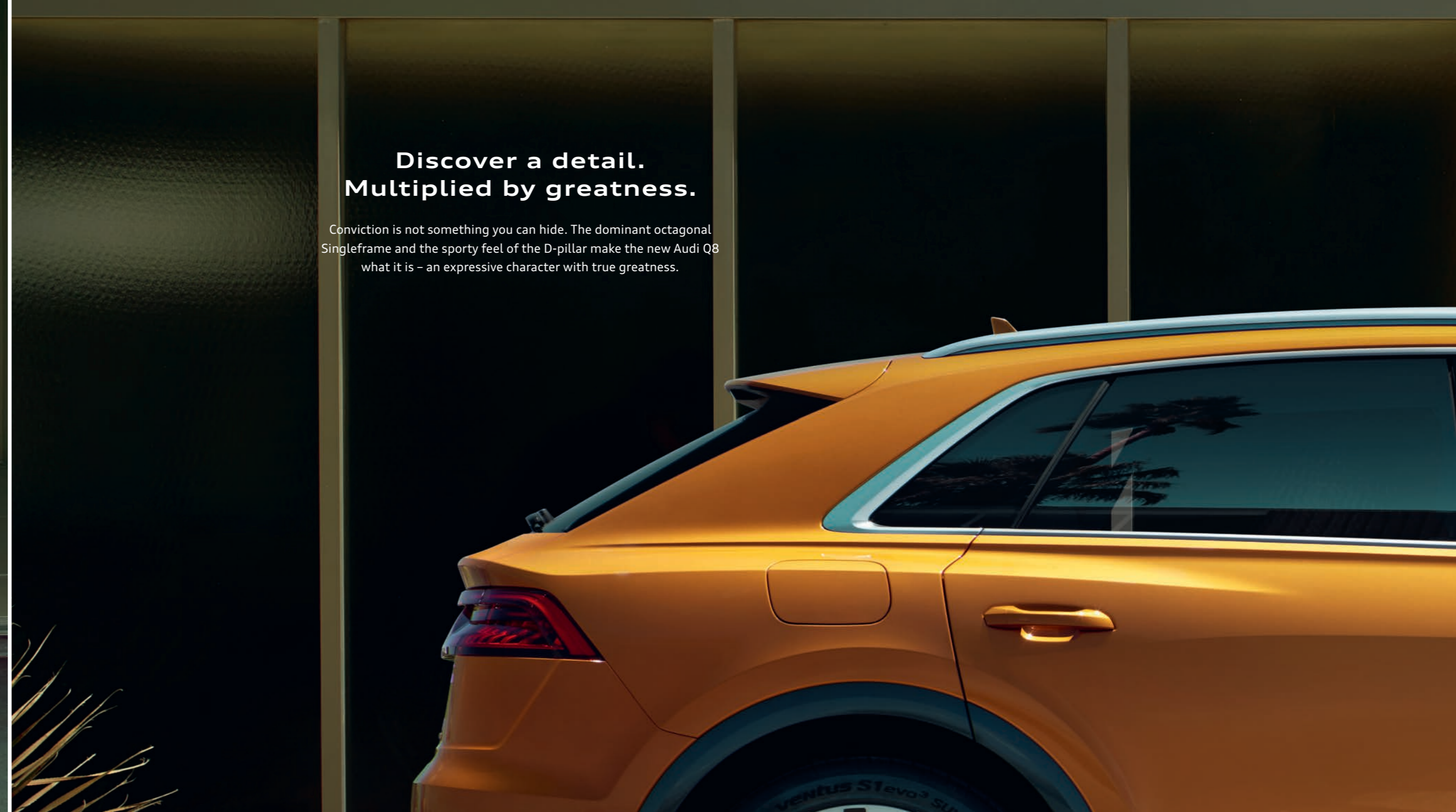



**Set yourself a challenge.
Driven by passion.**

For a driving experience in a whole other dimension. The new Audi Q8 combines luxurious comfort with superb handling stability. Thanks to the adaptive air suspension, it adjusts to your individual driving style and ensures superb cornering and a sporty, direct steering sensation on virtually any terrain.

Driving around town usually means you have somewhere to be. The new Audi Q8 helps you get there without you losing your cool. Its standard all-wheel steering and ideal power distribution to both axles provide the agility and manoeuvrability you need – even to negotiate the urban jungle. That way you can stay relaxed even on tight bends. For an extraordinary driving sensation. Intensified with Audi quattro.





**Think about mobility.
Designed for peace of mind.**

We move around more freely than ever before, and yet everything we need can travel with us. All thanks to new technologies that bring clarity to our daily lives. This includes the digital core, a new design approach that focuses on the essentials while opening up endless possibilities. In this way, the new Audi Q8 combines a clear menu structure with the latest personalisation options.

The image shows the interior of a luxury car, focusing on the front seats and the center console. The seats are upholstered in dark leather with a perforated texture. The center console features a gear shifter and a digital display. The dashboard and steering wheel are also visible, with a digital instrument cluster. The car is parked in a well-lit area, possibly a parking garage, with a sign that reads "CLEARANCE 7' 5\"/>

**Enjoy relaxation.
Refined with exclusivity.**

Whether it's by getting your day off to a good start or having a relaxed journey home – we all need ways to offset the rigours of everyday life. And it shouldn't be any different when you're setting off on holiday. With seat ventilation functions of the front customised contour seats in Valcona leather, time takes on a whole new dimension.

Create a familiar place. Framed by openness.

A quick look at your options. The new Audi Q8 – an exceptional vehicle whose diverse range of high-quality equipment will impress you. Innovation and comfort meet individuality and personality. Tailored to your wishes.

Standard panoramic glass sunroof – provides for a pleasant, well-lit interior and improved interior climate thanks to efficient ventilation. An integrated wind deflector reduces wind noise when the sunroof is open. And the electrically operated, virtually lightproof sunblind means you don't have to worry about strong sunlight.



MMI navigation plus
with MMI touch response



Think about seeing.
Multiplied by being seen.

For a statement that clearly makes an impression:
the new LED rear light band on the new Audi Q8.

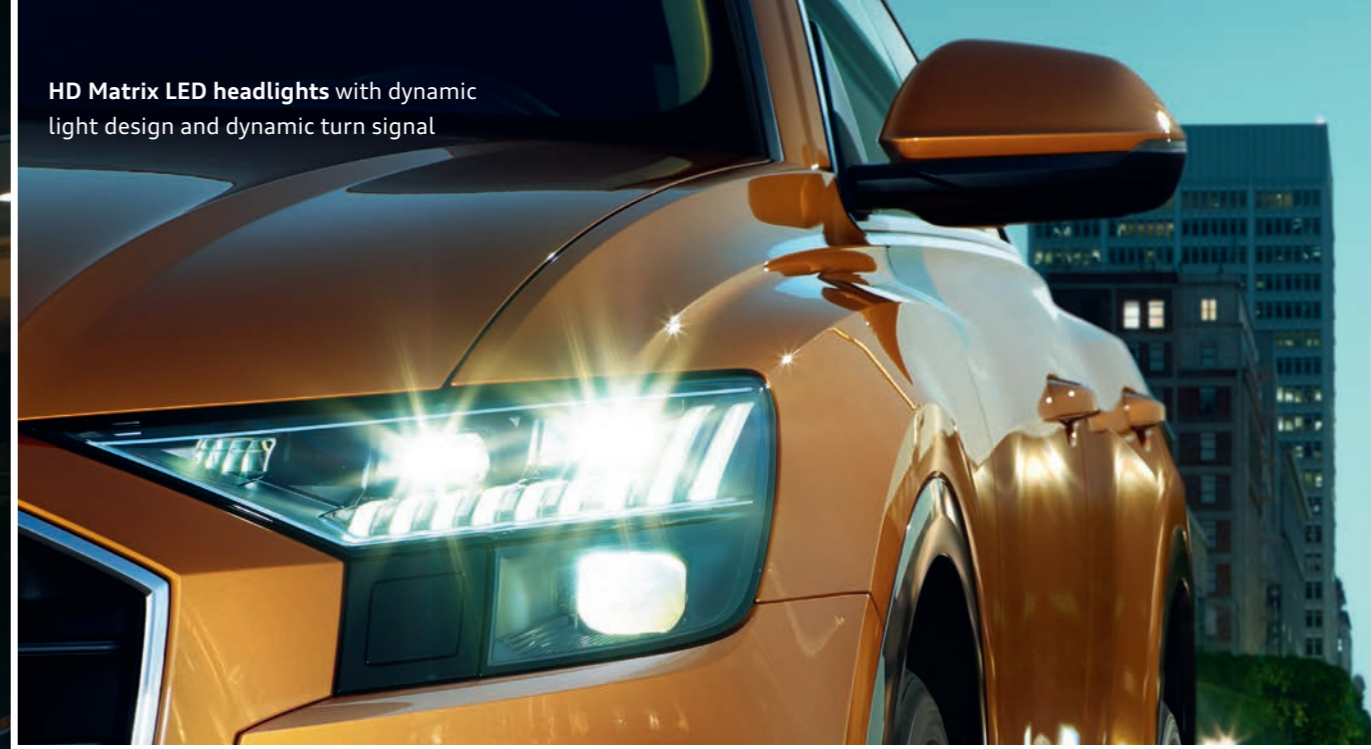

HD Matrix LED headlights with dynamic light design and dynamic turn signal



**Discover an interior.
Tailored to your mood.**

For a driving sensation that speaks to all the senses and conveys pure lightness –
underlined by a centre console that appears to float freely in the cockpit.





Town or country: Audi quattro with self-locking centre differential ensures the necessary reliability – even when the drive gets challenging. Wheel-selective torque control provides additional support to the permanent all-wheel drive with asymmetric, dynamic torque distribution.

**Savour the sight.
Rendered for a lasting impression.**

When you choose a paint colour, choose one that best matches your own personality. Secure in the knowledge that the quality will be superb, because your vehicle is painted not just once, but four times. So not only do you look radiant in your Audi, that car is also protected from many environmental influences as well as wear. Ensuring that the car remains a powerful sight throughout its entire lifetime.



- 01 Dragon orange, metallic
- 02 Navarra blue*, metallic
- 03 Glacier white, metallic
- 04 Galaxy blue, metallic
- 05 Cobra beige, metallic
- 06 Samurai grey, metallic

*Navarra blue is not available in the market

Model	Q8 3.0 TFSI quattro tiptronic
Engine type	V6 engine with direct fuel injection, exhaust turbocharging and Audi valvelift system, Mild Hybrid Electric Vehicle (MHEV)
Displacement in cc (valves per cylinder)	2,995 (4)
Max. output in kW(hp) at rpm	250 (340) / 5,200 – 6,400
Max. torque in Nm at rpm	500 / 1,370 – 4,500
Power transmission	
Drive type	quattro permanent all-wheel drive
Transmission type	8-speed tiptronic transmission
Weights/capacities	
Unladen weight in kg	2,165
Max laden weight in kg	2,815
Permissible roof load limit in kg	100
Fuel tank capacity in l	85
Performance/consumption	
Top speed in km/h	250
Acceleration 0–100 km/h in s	5.9
Fuel grade	Sulphur-free RON 95
Fuel consumption (combined) in l/100 km	8.9
Emission standard	EU6



20" cast alloy wheels, 5 arm style design

Audi Q8 Dimensions in mm

Dimensions are based on technical data from Audi Germany. Dimensions are for unladen vehicle weight. Luggage capacity: 605 l (second value is with the rear seat backrest folded down and the vehicle loaded up to roof height). Turning circle approx. 13.3 m. *Maximum headroom. **Elbow room width. ***Shoulder room width. ****Vehicle height with roof aerial.

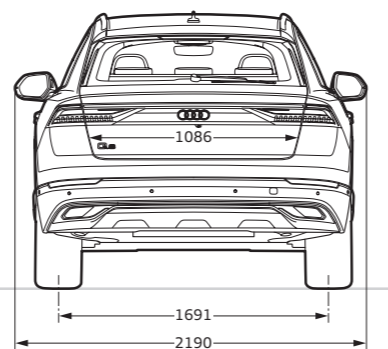
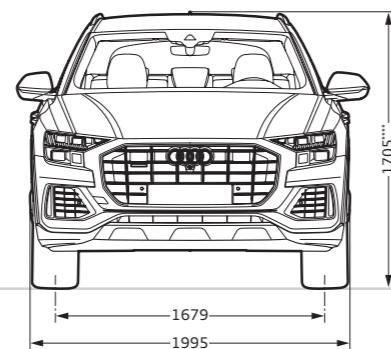
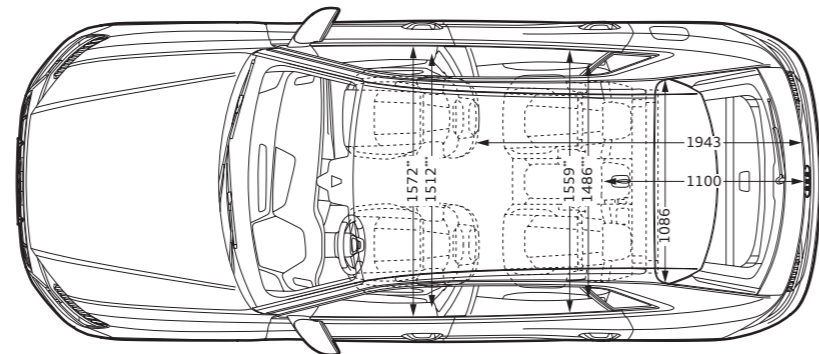
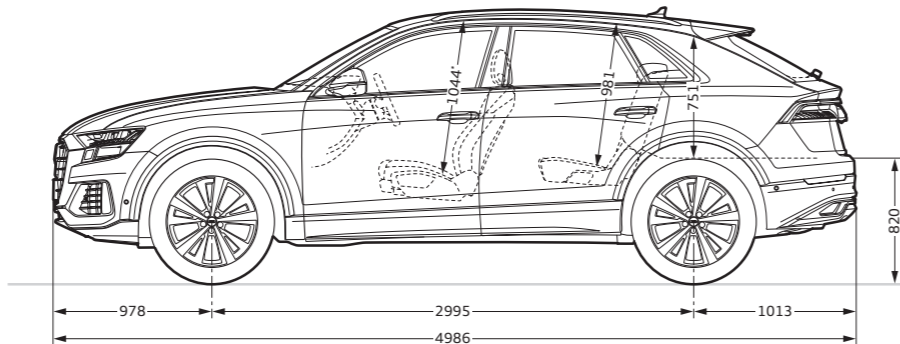

Audi Malaysia

A business division of Volkswagen Group Malaysia (“VGM”)

www.audi.com.my

Printed February 2019

The models and equipment versions illustrated and described in this brochure and some of the services listed are not available in all countries. Some of the cars illustrated are equipped with optional features for which an extra charge is made. Details concerning the delivery specifications, appearance, performance, dimensions and weights, fuel consumption and running costs of the vehicle were correct to the best of our knowledge at the time of going to press. Deviations from the colours and shapes shown in the illustrations may occur. No liability is accepted for errors and printing errors.

