



Q5



Now is calling.



**Created for almost every landscape:
The all-new Audi Q5.**

Don't leave anything to chance. Regardless of comfort, style or driving dynamics, this premium SUV is all-rounded. From its appearance, drive, to its pioneering technology, the all-new Audi Q5 is versatile for your daily adventure.

Developed to move you.

Even when at a standstill.

Every detail of the all-new Audi Q5 is characterised by the typical Q design and embodies dynamism and confidence. Like the striking bonnet or the gently sloping roof line, the exterior mirrors on the shoulders and the slim window line. The partly polished cast aluminium wheels in 5-segment-spoke design in contrasting grey define sportiness and leaves you with an impression, even off-road.



Give light a whole new design: Audi LED headlights.

The all-new Audi Q5 comes standard with LED daytime running lights and rear dynamic indicators. The headlights automatically adapt to road conditions for better visibility while the newly sculpted radiator grille places an emphasis on the width and strength of the all-new Audi Q5.





One of the strengths of quattro lies in recognising the right moment.

Ready for almost any challenges on the road. The all-new Audi Q5 offers a quattro all-wheel drive system with ultra technology. For all 4-cylinder engines with quattro permanent all-wheel drive, an intelligent operating strategy ensures that your Q5 is efficient, dynamic and safe – with the usual traction. If quattro is not required, it switches off, thus helping the driver to save fuel. The all-wheel drive remains permanently available, of course. If quattro is required during the drive, a balanced distribution of power is applied on various road conditions.

**Does not skimp on power.
But helps save fuel.**

The TFSI engine makes the all-new Audi Q5 efficient and perceptibly powerful. The 4-cylinder engines make an impression by enhancing performance. In addition, the quattro all-wheel drive guarantees a better response during steering and acceleration. The start-stop system gives the vehicle more fuel efficiency, reducing consumption without compromising performance.





Demonstrates greatness. In every detail.

The all-new Audi Q5 has a longer wheelbase, more generous amount of space and practical storage options. The standard luggage compartment roller cover and the optional luggage compartment mat allow you to adapt the luggage compartment exactly to your requirements. The remote backrest release allows the rear seat backrests to be folded, giving more than double the luggage space. The standard sensor-controlled luggage compartment release makes loading even easier. If your hands are full, open the tailgate by moving your foot for storing heavy items at ease.

Enthusiasm drives power.

It creates the need to explore in new drives ahead. Discover the all-new Audi Q5.



Easy to operate. Hard to miss.

The large, slim 8.3-inch colour display in the MMI navigation plus offers impressive clarity and a straightforward operating concept, so that you are well informed in no time at all. Whether navigation, radio, or phone – fewer buttons lead you to more functions. Quickly, intuitively and with MMI touch on request, control everything via touchscreen or voice control. The Audi smartphone interface integrates selected mobile phone content into your Audi and turns the screen into a smartphone display.



Everything at a glance. At the right moment.

The standard Audi virtual cockpit makes progress visible. The fully digital instrument cluster with high-resolution 12.3-inch screen displays a wide range of driver-related information. From speed to navigation and communication – you choose from numerous display options. And have the future in sight.

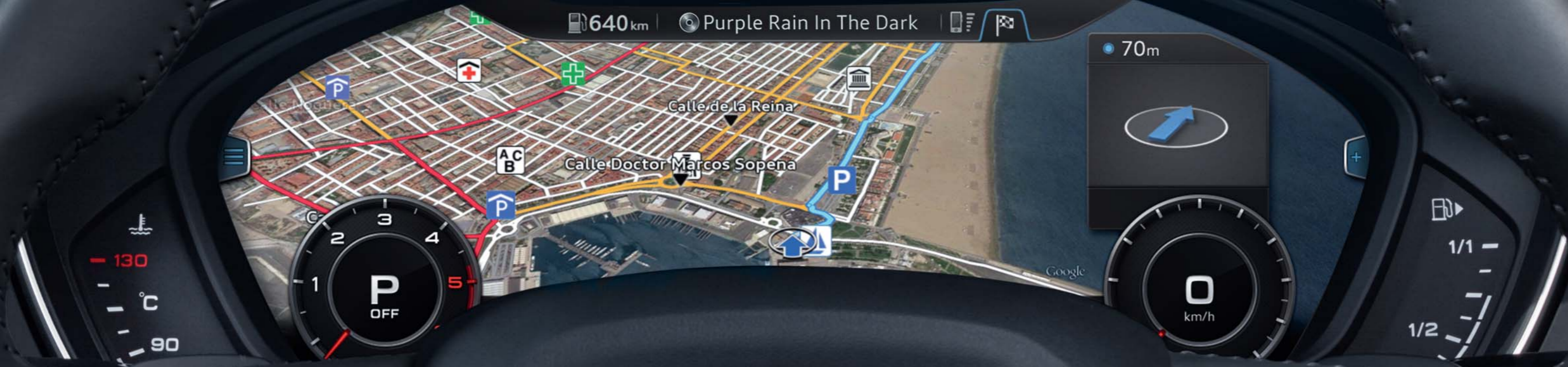



Powerful look.

When you choose a paint colour, choose one that best matches your own personality. Rest assured that the quality will be at its finest as your vehicle is painted not just once, but four times. Apart from looking radiant, the car is also protected from environmental influences, wear and tear, yet maintaining a powerful look throughout its entire lifetime.

*Utopia blue is not available in the market. Quantum grey is available.
 *Actual product might differ. Images are for illustration purposes only.

Mythos black,
metallic

Manhattan grey,
metallic

Azores green,
metallic

Java brown,
metallic

Utopia blue*,
metallic

Matador red,
metallic

Floret silver,
metallic

Daytona grey,
pearl effect

Model	
Engine type	4-cylinder inline petrol engine with direct fuel injection, turbocharging and Audi valvelift system
Displacement in cc (valves per cylinder)	1,984 (4)
Max. output in kW (hp) at rpm	185 (252)
Max. torque in Nm at rpm	370 / 1,600 - 4,500
Power Transmission	
Drive type	quattro permanent all-wheel drive with ultra technology
Transmission type	7-speed S tronic
Weights/capacities	
Unladen weight in kg	1,795
Gross vehicle weight in kg	2,400
Permissible roof load limit/nose weight in kg	75 / 100
Trailer load limit in kg unbraked	750
Fuel tank capacity, approx. in l	70
Performance/consumption	
Top speed in km/h	237
Acceleration 0-100 km/h in s	6.3
Fuel grade	Sulphur-free super RON 95
Fuel consumption (combined) in l/100km	TBA
Emission standard	EU6

Audi Q5 2.0 TFSI quattro (185kW)

2.0-litre four-cylinder TFSI engine in the Audi Q5 with FSI - petrol direct injection, turbocharger, integrated exhaust gas cooling in the cylinder head, electronically controlled coolant control and Audi valvelift on the exhaust camshaft.

1,984cm³
252 (hp) @ 5,000 - 6,000min⁻¹
370Nm @ 1,600 - 4,500min⁻¹

TFSI®



19" cast aluminium wheels in 5-spoke dynamic design, partly polished.

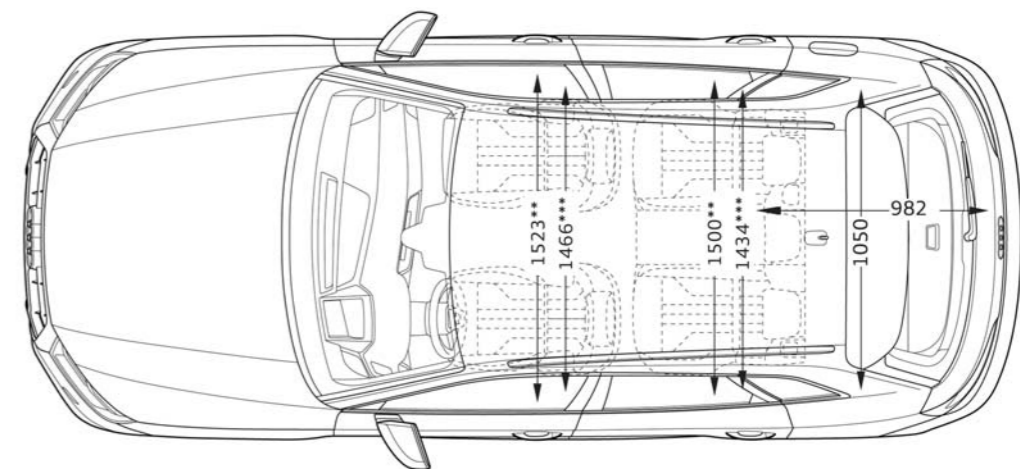
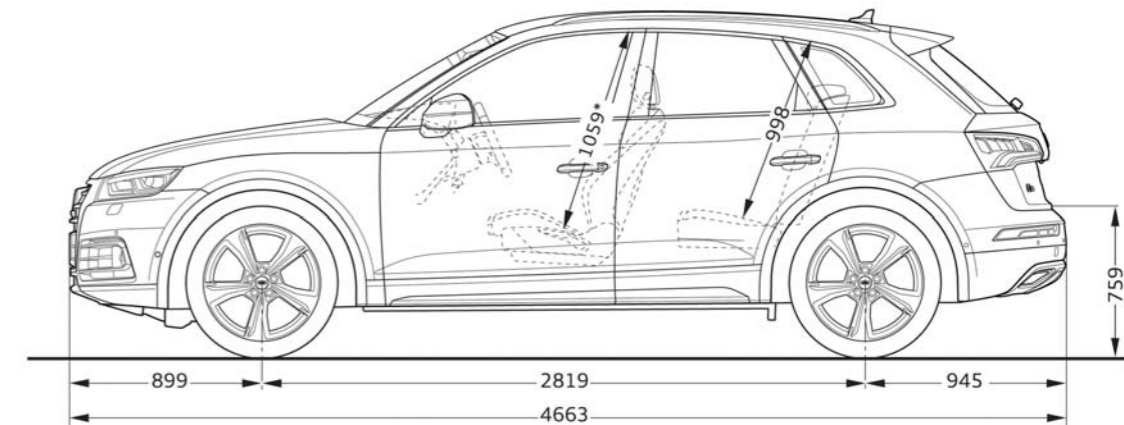
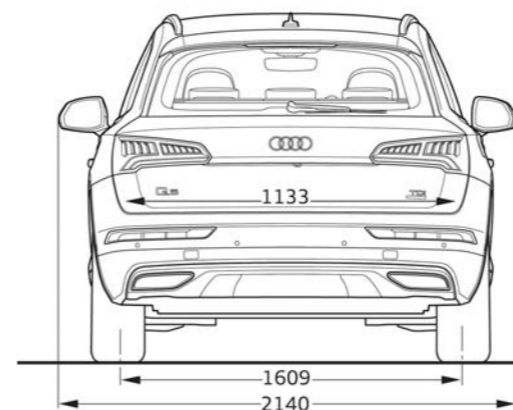
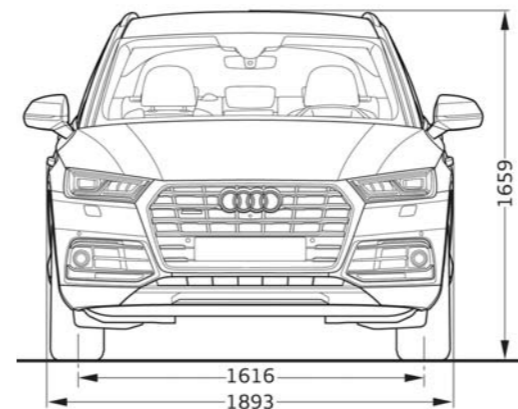

Dimensions in mm

Dimensions are for unladen vehicle weight. Luggage capacity: 550/610/1,550 l (second value with optionally movable rear seat bench and bench moved as far forward as possible; third value with rear seat backrest folded down and loaded up to the parcel shelf). Turning circle approx. 11.7 m. * Maximum headroom **Elbow room width ***Shoulder room width

Audi Malaysia

A business division of Volkswagen Group Malaysia (“VGM”)
www.audi.com.my

Printed December 2018

The models and equipment versions illustrated and described in this brochure and some of the services listed are not available in all countries. Some of the cars illustrated are equipped with optional features for which an extra charge is made. Details concerning the delivery specifications, appearance, performance, dimensions and weights, fuel consumption and running costs of the vehicle were correct to the best of our knowledge at the time of going to press. Deviations from the colours and shapes shown in the illustrations may occur. No liability is accepted for errors and printing errors.

